

Poly Single Axle Fenders



- ◆ Long lasting high density polyethylene construction
- ◆ Corrosion, wear and UV resistant
- ◆ Lightweight
- ◆ Easy to clean and maintain



Pair Part #: **NF180PX**
Single Part #: **NF180PX-1**

- ◆ Black poly fender(s)
- ◆ 76" overall length
- ◆ 24" width
- ◆ Weight: 21 lbs (pair)
- ◆ See colour choices below

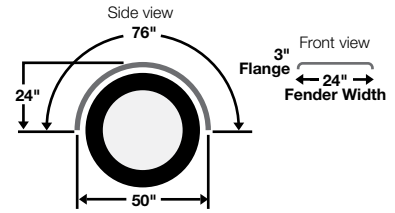

See Poly Video:
Scan or go to nuline.ca ...
choose "Gallery" ...
choose "Videos"

Pair Part #: **NF18026PX**
Single Part #: **NF18026PX-1**

- ◆ Black poly fender(s)
- ◆ 79" overall length
- ◆ 26" width (2" wider than NF180PX)
- ◆ Weight: 21 lbs (pair)

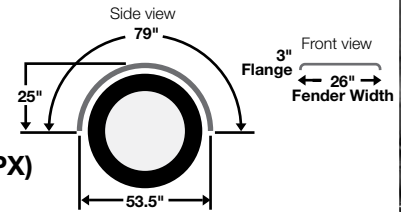

Pair Part #: **NF166PX**
Single Part #: **NF166PX-1**

- ◆ Black poly fender(s)
- ◆ 64" overall length
- ◆ 24" width
- ◆ Weight: 19 lbs (pair)

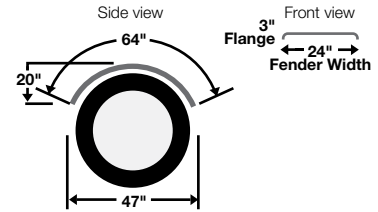

Black Poly Full Tandem Fenders



Pair Part #: **NF13254PX**
Single Part #: **NF13254PX-1**

- ◆ Black poly fender(s)
- ◆ 131" overall length
- ◆ 26" width
- ◆ Weight: 48 lbs (pair)

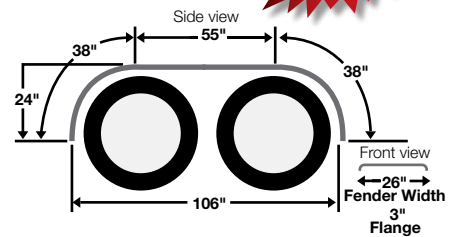

Black Poly Half Tandem Fenders



Available in multiple colours;
10 pair minimum order.
8 week lead time.

Pair Part #: **NF66PX**
Single Part #: **NF66PX-1**

- ◆ Black poly fender(s)
- ◆ 66" overall length
- ◆ 26" width
- ◆ Weight: 22 lbs (pair)

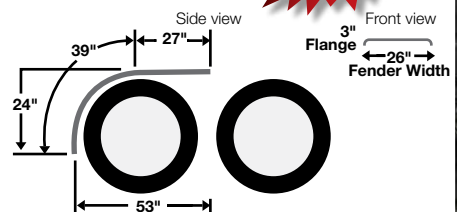

* All Nu-Line Poly fenders feature a limited lifetime product warranty. Warranty is non-transferable and applies to installation on one vehicle. Contact Nu-Line for warranty details.

Poly Quarter Fender

Lifetime Warranty*



Pair Part #: **N1900-KIT**

Driver Side: **N1900-L**

Passenger Side: **N1900-R**

- ◆ Two polyethylene fenders
- ◆ Two top flaps with hardware
- ◆ Two black clamps
- ◆ 24" length
- ◆ Weight: 20 lbs (pair)

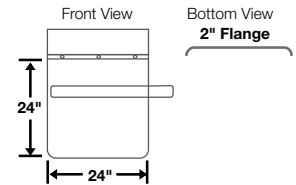

Poly Mounting Kits

Recommended single axle and full tandem mounting kit:

N180PMK



Recommended:

Order **N230** center mounts separately. Need left hand and right hand models. See page 16 for centre mount information.

Recommended half tandem mounting kit:

N66PMKXB



Recommended:

Order **N230** center mounts separately. Need Left hand and right hand. See page 16 for centre mount information.

Poly Super Single Fenders



Lifetime Warranty*



Pair Part #: **NF180PX-19**

Single Part #: **NF180PX-19-1**

- ◆ Super single axle poly fender(s)
- ◆ 76" overall length
- ◆ 19" width
- ◆ Weight: 16 lbs (pair)

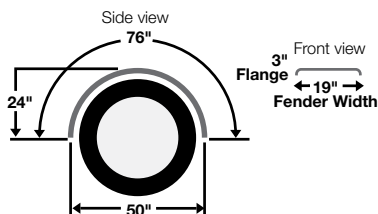

Pair Part #: **NF66PX-19**

Single Part #: **NF66PX-19-1**

- ◆ Super single poly half tandem fender(s)
- ◆ 66" overall length
- ◆ 19" width
- ◆ Weight: 17 lbs (pair)

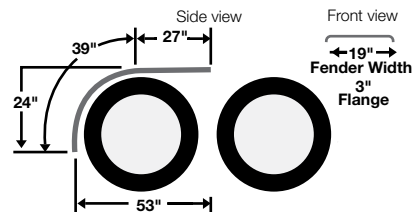

* All Nu-Line Poly fenders feature a limited lifetime product warranty. Warranty is non-transferable and applies to installation on one vehicle. Contact Nu-Line for warranty details.

Stainless Steel Quarter Fenders



Part #: N224-SS

- ◆ Two 18 gauge stainless steel fenders
- ◆ Two N200-SS7 mounting arms
- ◆ Two top flaps with hardware
- ◆ Two stainless steel clamps
- ◆ 24" length
- ◆ Weight: 35 lbs (pair)

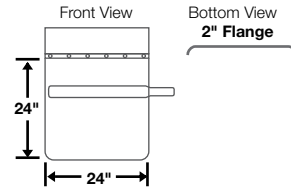

Part #: N224-SSB

- ◆ Two 18 gauge stainless steel fenders
- ◆ Two mounting pipes
- ◆ Six mounting braces
- ◆ Two top flaps with hardware
- ◆ Two stainless steel clamps
- ◆ 24" length
- ◆ Weight: 30 lbs (pair)

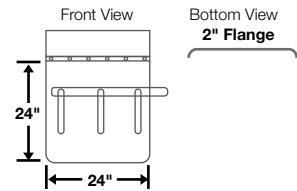

Part #: N227-SS

- ◆ Two 18 gauge stainless steel fenders
- ◆ Two N200-SS7 mounting arms
- ◆ Two top flaps with hardware
- ◆ Two stainless steel clamps
- ◆ 26" length
- ◆ Weight: 35 lbs (pair)

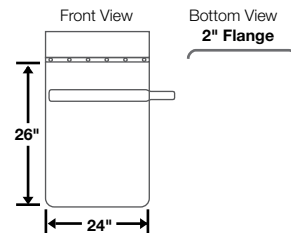

Part #: 1585-FB

- ◆ Two 18 gauge stainless steel fenders
- ◆ Two top flaps with hardware
- ◆ Two stainless steel clamps
- ◆ 22" length
- ◆ Weight: 32 lbs (pair)

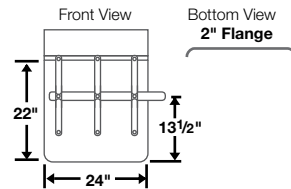

Part #: 1585-LM

- ◆ Two 18 gauge stainless steel fenders
- ◆ Two top flaps with hardware
- ◆ Two stainless steel clamps
- ◆ 22" length
- ◆ Weight: 29 lbs (pair)

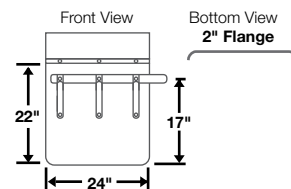

1000 Series



Also available:
 NF1060SSNRLF
 NF1066SSNRLF
 NF1080SSNR

Pair Part #: **NF1060SSNR**
 Single Part #: **NF1060SSNR-1**

- ◆ 16 gauge stainless steel fender(s)
- ◆ 60" overall length
- ◆ 24" width
- ◆ Weight: 52 lbs (pair)

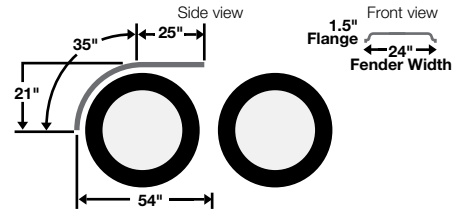

Pair Part #: **NF1066SSNR**
 Single Part #: **NF1066SSNR-1**

- ◆ 16 gauge stainless steel fender(s)
- ◆ 66" overall length
- ◆ 24" width
- ◆ Weight: 58 lbs (pair)

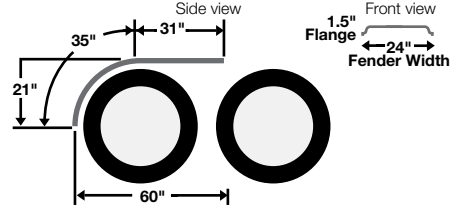

NF Series



Pair Part #: **NF60SS**
 Single Part #: **NF60SS-1**

- ◆ 16 gauge stainless steel fender(s)
- ◆ 60" overall length
- ◆ 24" width
- ◆ Weight: 52 lbs (pair)

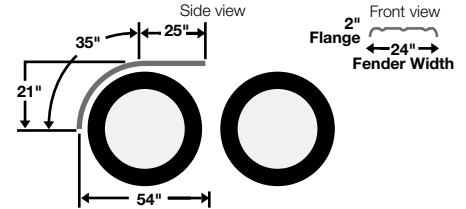

Pair Part #: **NF66SS**
 Single Part #: **NF66SS-1**

- ◆ 16 gauge stainless steel fender(s)
- ◆ 66" overall length
- ◆ 24" width
- ◆ Weight: 60 lbs (pair)

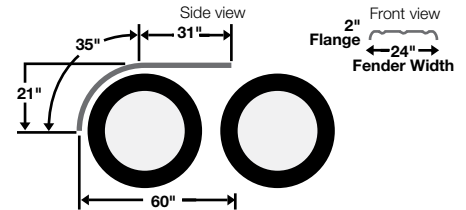

Pro Series



Pair Part #: **NF66SSNR**
 Single Part #: **NF66SSNR-1**

- ◆ 14 gauge stainless steel fender(s)
- ◆ 66" overall length
- ◆ 24" width
- ◆ Weight: 76 lbs (pair)

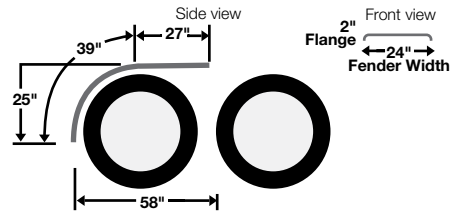

Use a mounting kit with heavy duty arms (N200-SS7HD)

N Series

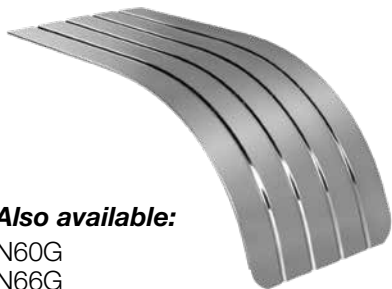

Also available:
 N60G
 N66G
 N80SS
 N80G
 N125SS
 N125G

Pair Part #: **N60SS**
 Single Part #: **N60SS-1**

- ◆ 18 gauge stainless steel fender(s)
- ◆ 60" overall length
- ◆ 24" width
- ◆ Weight: 44 lbs (pair)

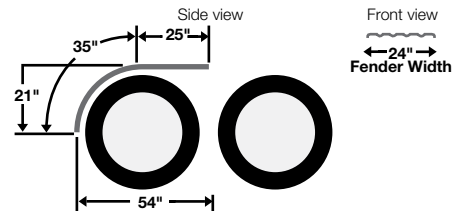

Pair Part #: **N66SS**
 Single Part #: **N66SS-1**

- ◆ 18 gauge stainless steel fender(s)
- ◆ 66" overall length
- ◆ 24" width
- ◆ Weight: 50 lbs (pair)

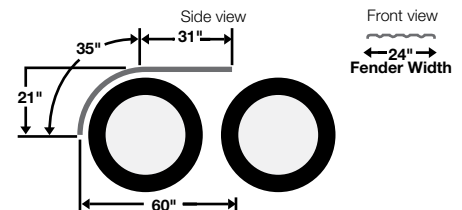

Half Tandem Fender Mounting Kit Options

(All kits mount one pair of fenders)

Part #: N260SSMKXB

Includes:

- 2 of N200-SS7
- 2 of N52
- 1 of N260SSHB

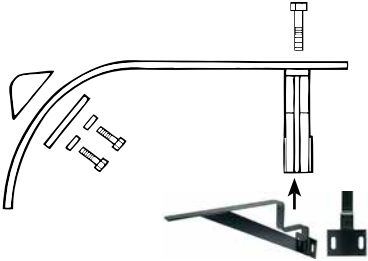

Order centre mounts separately on page 16.



N200-SS7



N260SSHB

Heavy duty version of this kit is: N260SSMKHDXB

Part #: N260SSMK

Includes:

- 2 of N200-SS7
- 2 of N230*
- 2 of N52
- 1 of N260SSHB

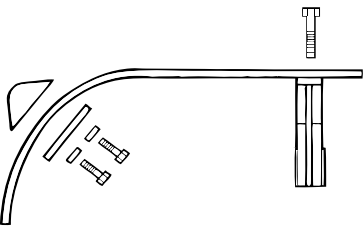

N200-SS7



N230*



N260SSHB

N52

Part #: N260SSMKUB

Includes:

- 2 of N200-SS7
- 1 of N230PMRH
- 1 of N230PMLH
- 2 of N52
- 1 of N260SSHB

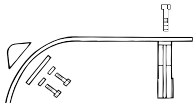

N260SSHB

N230PMRH

N230PMLH

N52

Part #: N8060SSMK

Includes:

- 1 of NC091-SS
- 2 of N230*
- 1 of N6080SSHB

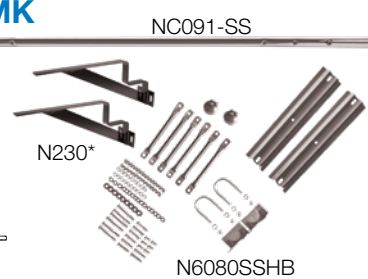
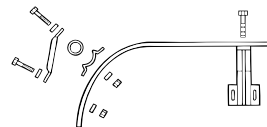

N6080SSHB

NC091-SS

N230*

*N230 is standard, other options available on page 16.

Additional kits available (www.nuline.ca)



1000 Series



Pair Part #: **NF10166SSNR**

Single Part #: **NF10166SSNR-1**

- ◆ 16 gauge stainless steel fender(s)
- ◆ 66" overall length
- ◆ 24" width
- ◆ Weight: 60 lbs (pair)

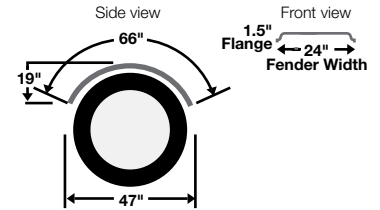

Pair Part #: **NF10180SSNR**

Single Part #: **NF10180SSNR-1**

- ◆ 16 gauge stainless steel fender(s)
- ◆ 80" overall length
- ◆ 24" width
- ◆ Weight: 70 lbs (pair)

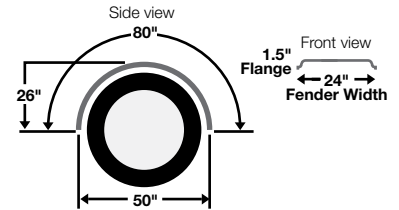

NF Series



Pair Part #: **NF155A**

Single Part #: **NF155A-1**

- ◆ .090" aluminum fender(s)
- ◆ 55" overall length
- ◆ 24" width
- ◆ Weight: 26 lbs (pair)

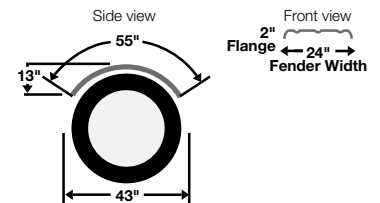

Pair Part #: **NF155SS**

Single Part #: **NF155SS-1**

- ◆ 16 gauge stainless steel fender(s)
- ◆ 55" overall length
- ◆ 24" width
- ◆ Weight: 48 lbs (pair)

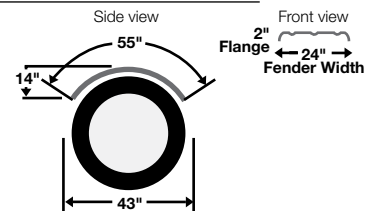

Pair Part #: **NF166A**

Single Part #: **NF166A-1**

- ◆ .090" aluminum fender(s)
- ◆ 66" overall length
- ◆ 24" width
- ◆ Weight: 32 lbs (pair)

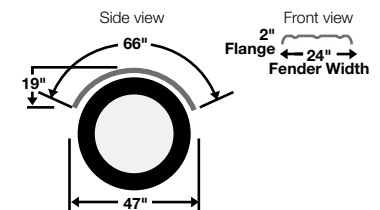

Also available:
NF166SS

Pair Part #: **NF180A**

Single Part #: **NF180A-1**

- ◆ .090" aluminum fender(s)
- ◆ 80" overall length
- ◆ 24" width
- ◆ Weight: 40 lbs (pair)

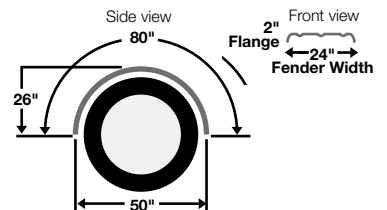

Pair Part #: **NF180SS**

Single Part #: **NF180SS-1**

- ◆ 16 gauge stainless steel fender(s)
- ◆ 80" overall length
- ◆ 24" width
- ◆ Weight: 70 lbs (pair)

Pro Series



Pair Part #: **NF166SSNR**

Single Part #: **NF166SSNR-1**

- ◆ 14 gauge stainless steel fender(s)
- ◆ 66" overall length
- ◆ 24" width
- ◆ Weight: 76 lbs (pair)

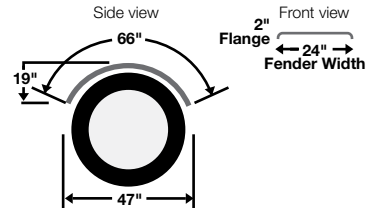

Pair Part #: **NF180SSNR**

Single Part #: **NF180SSNR-1**

- ◆ 14 gauge stainless steel fender(s)
- ◆ 80" overall length
- ◆ 24" width
- ◆ Weight: 92 lbs (pair)

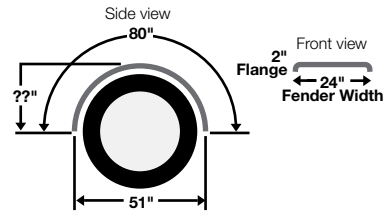

Use a mounting kit with heavy duty arms (N200-SS7HD)

N Series



Also available:

N180G
N155SS
N155G

Pair Part #: **N180SS**

Single Part #: **N180SS-1**

- ◆ 18 gauge stainless steel fender(s)
- ◆ 80" overall length
- ◆ 24" width
- ◆ Weight: 60 lbs (pair)

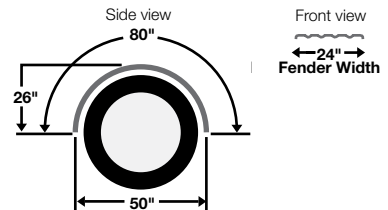

Single Axle Fender Mounting Kits

All kits mount one pair of fenders

Part #: **N2180SSMK**

Includes

- 4 of N200-SS7
- 4 of N52
- 1 of N2180SSHB

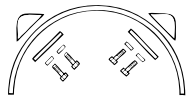

Heavy duty version of this kit is:
N2180SSMKHD

Part #: **N180GMK**

Includes

- 4 of N30
- 1 of N180GHB

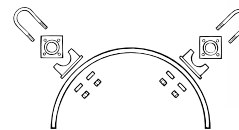
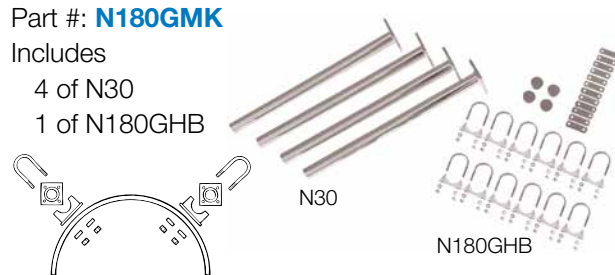

Part #: **N2180PMK**

Includes

- 4 of N200-SS7-BLK powder coated
- 4 of N52
- 1 of N2180SSHB

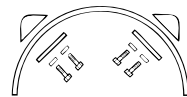

Part #: **N180GMK-PM**

Includes

- 4 of N40
- 1 of N180GHB

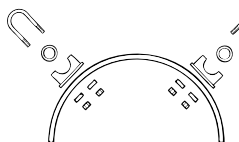
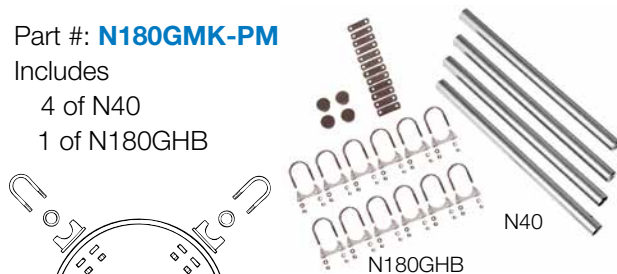

Additional kits available (www.nuline.ca)



1000 Series



Also available:
 NF1012060SSNR
 NF1012554SSNR

Pair Part #: **NF1012054SSNR**
 Single Part #: **NF1012054SSNR-1**

- ◆ 16 gauge stainless steel fender(s)
- ◆ 120" overall length
- ◆ 24" width
- ◆ Weight: 106 lbs (pair)

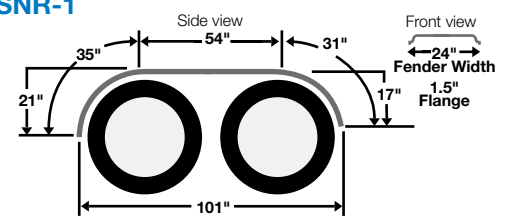

NF Series



Also available:
 NF120A
 NF120SS
 NF126SS
 NF12054A

Pair Part #: **NF12054SS**
 Single Part #: **NF12054SS-1**

- ◆ 16 gauge stainless steel fender(s)
- ◆ 120" overall length
- ◆ 24" width
- ◆ Weight: 106 lbs (pair)

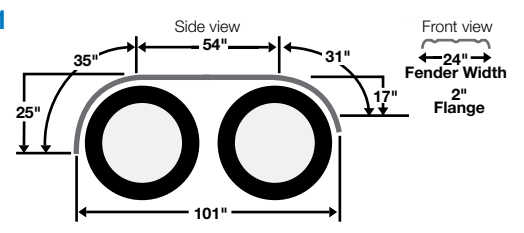

Pro Series



Also available:
 NF142SSNR

Pair Part #: **NF13254SSNR**
 Single Part #: **NF13254SSNR-1**

- ◆ 14 gauge stainless steel fender(s)
- ◆ 132" overall length
- ◆ 24" width
- ◆ Weight: 150 lbs (pair)

Use a mounting kit with heavy duty arms (N200-SS7HD)

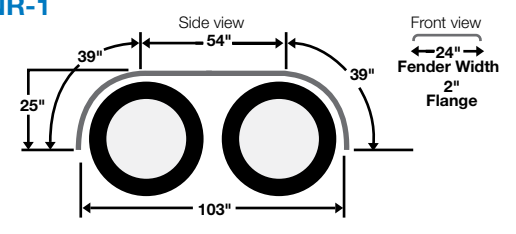

N Series



Also available:
 N120SS
 N120G
 N12054G

Pair Part #: **N12054SS**
 Single Part #: **N12054SS-1**

- ◆ 18 gauge stainless steel fender(s)
- ◆ 120" overall length
- ◆ 24" width
- ◆ Weight: 88 lbs (pair)

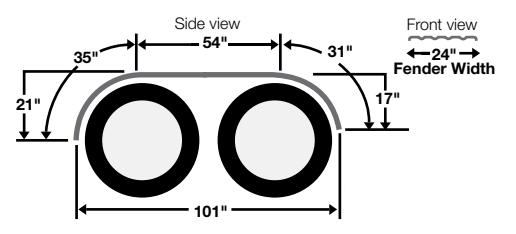

Full Tandem Mounting Kit Options

(All kits mount one pair of fenders)

Part #: N2120SSMKXB

Includes:

- 4 of N200-SS7
- 4 of N52
- 1 of N2120SSHB

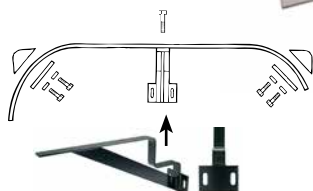

Heavy duty version of this kit is:
N2120SSMKHDXB

Order centre mounts separately on page 16

Part #: N2120SSMK

Includes:

- 4 of N200-SS7
- 4 of N52
- 2 of N230*
- 1 of N2120SSHB

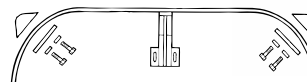

*N230 is standard, other options available on page 16.

Additional kits available (www.nuline.ca)

Download Flyers and Videos www.nuline.ca

Choose "Nu-Line" Menu and then choose "Literature".



Choose "Nu-Line" Menu and then choose "Videos".

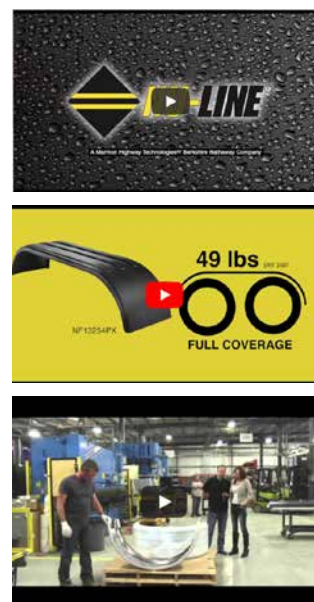

www.nuline.ca

Tanker Fenders

Full Tandem Flanged 3 Rib



- Pair Part #: **NF99A**
 Single Part #: **NF99A-1**
- ◆ .090" aluminum fender(s)
 - ◆ 108" overall length
 - ◆ 24" width
 - ◆ Weight: 52 lbs (pair)

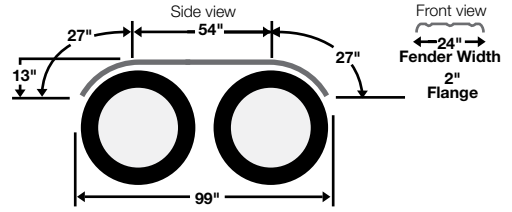

- Pair Part #: **NF96ARU**
 Single Part #: **NF96ARU-1**
- ◆ .090" aluminum fender(s)
 - ◆ **Ribs up** design
 - ◆ 107" overall length
 - ◆ 25" width
 - ◆ Weight: 52 lbs (pair)

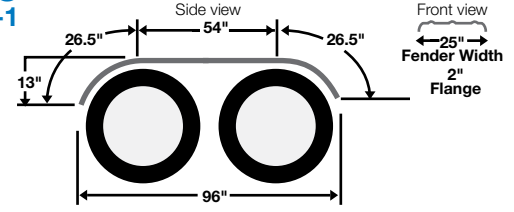

- Pair Part #: **NF99SS**
 Single Part #: **NF99SS-1**
- ◆ 16 gauge stainless steel fender(s)
 - ◆ 108" overall length
 - ◆ 24" width
 - ◆ Weight: 94 lbs (pair)

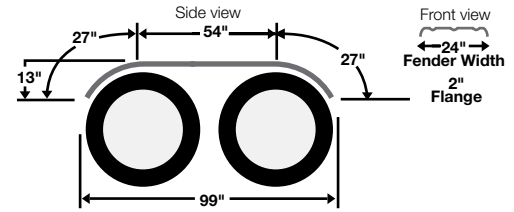

- Pair Part #: **NF96SSRU**
 Single Part #: **NF96SSRU-1**
- ◆ .090" stainless steel fender(s)
 - ◆ **Ribs up** design
 - ◆ 107" overall length
 - ◆ 25" width
 - ◆ Weight: 52 lbs (pair)

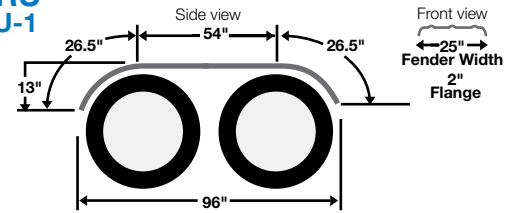

Half Tandem Flanged 3 Rib



- Pair Part #: **NF139A**
 Single Part #: **NF139A-1**
- ◆ .090" aluminum fender(s)
 - ◆ 144" overall length
 - ◆ 24" width
 - ◆ Weight: 68 lbs (pair)

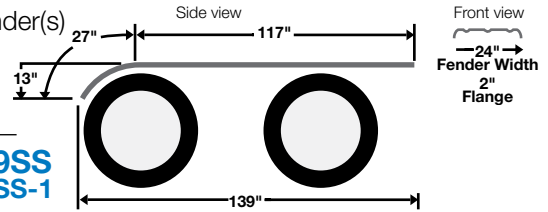

- Pair Part #: **NF139SS**
 Single Part #: **NF139SS-1**
- ◆ 16 gauge stainless steel fender(s)
 - ◆ 144" overall length
 - ◆ 24" width
 - ◆ Weight: 126 lbs (pair)



- Pair Part #: **NF139ARU**
 Single Part #: **NF139ARU-1**
- ◆ .090" aluminum fender(s)
 - ◆ **Ribs up** construction
 - ◆ 144" overall length
 - ◆ 25" width
 - ◆ Weight: 68 lbs (pair)

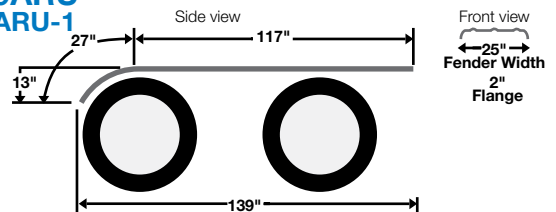

- Pair Part #: **NF139SSRU**
 Single Part #: **NF139SSRU-1**
- ◆ .090" stainless steel fender(s)
 - ◆ **Ribs up** construction
 - ◆ 144" overall length
 - ◆ 25" width
 - ◆ Weight: 68 lbs (pair)

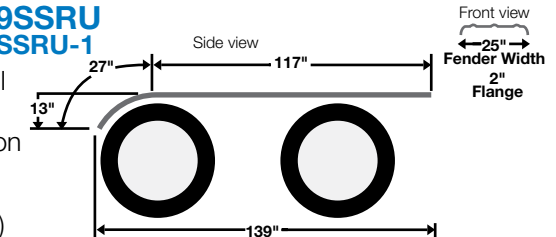

Tanker Fenders

Half Tandem Flanged 3 Rib



Pair Part #: **NF122A**
Single Part #: **NF122A-1**

- ◆ .090" aluminum fender(s)
- ◆ 125" overall length
- ◆ 24" width
- ◆ Weight: 60 lbs (pair)

Pair Part #: **NF122SS**
Single Part #: **NF122SS-1**

- ◆ 16 gauge stainless steel fender(s)
- ◆ 125" overall length
- ◆ 24" width
- ◆ Weight: 110 lbs (pair)

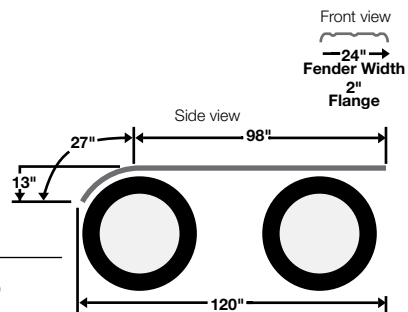

Pair Part #: **NF150A**
Single Part #: **NF150A-1**

- ◆ .090" tri-axle half tandem aluminum fender(s)
- ◆ 155" overall length
- ◆ 24" width
- ◆ Weight: 74 lbs (pair)

Pair Part #: **NF150SS**
Single Part #: **NF150SS-1**

- ◆ 16 gauge tri-axle half tandem stainless steel fender(s)
- ◆ 155" overall length
- ◆ 24" width
- ◆ Weight: 136 lbs (pair)

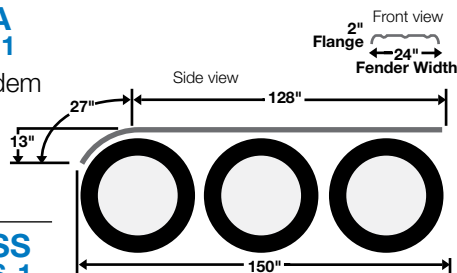

Also available:

- NF66A (Aluminum)
- NF80SS (Stainless Steel)
- NF125A (Aluminum)
- NF125SS (Stainless Steel)

Single Axle Flanged 3 Rib



Pair Part #: **NF166A**
Single Part #: **NF166A-1**

- ◆ .090" aluminum fender(s)
- ◆ 66" overall length
- ◆ 24" width
- ◆ Weight: 32 lbs (pair)

Pair Part #: **NF166SS**
Single Part #: **NF166SS-1**

- ◆ 16 gauge stainless steel fender(s)
- ◆ 66" overall length
- ◆ 24" width
- ◆ Weight: 60 lbs (pair)

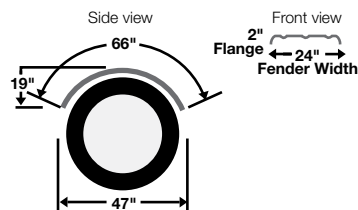

Also available:

- NF155SS
- NF160SS

Super Single Tanker Fenders



Pair Part #: **NF139A-19**
Single Part #: **NF139A-19-1**

- ◆ .090" aluminum fender(s)
- ◆ 144" overall length
- ◆ 24" width
- ◆ Weight: 55 lbs (pair)

Pair Part #: **NF99A-19**
Single Part #: **NF99A-19-1**

- ◆ .090" aluminum fender(s)
- ◆ 108" overall length
- ◆ 19" width
- ◆ Weight: 41 lbs (pair)

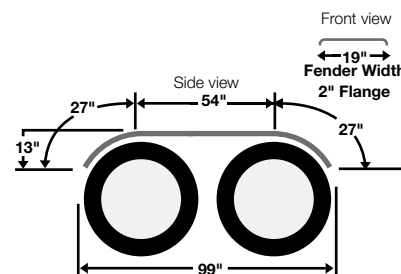
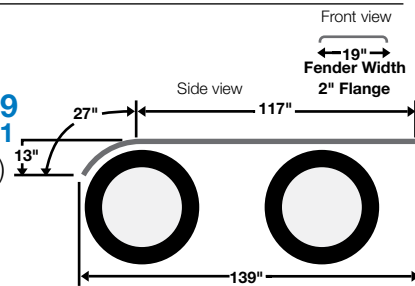

ACP Aluminum Checker Plate Fenders

Half Tandem



Pair Part #: **NF66ACP**
 Single Part #: **NF66ACP-1**

- ◆ .100" aluminum fender(s)
- ◆ 66" overall length
- ◆ 24" width
- ◆ Weight: 38 lbs (pair)

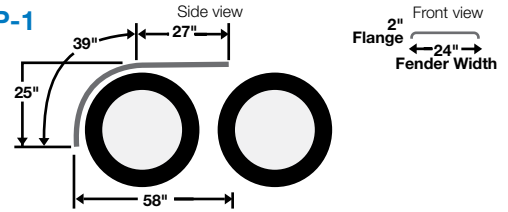

Full Tandem



Pair Part #: **NF12054ACP**
 Single Part #: **NF12054ACP-1**

- ◆ .100" aluminum fender(s)
- ◆ 120" overall length
- ◆ 24" width
- ◆ Weight: 75 lbs (pair)

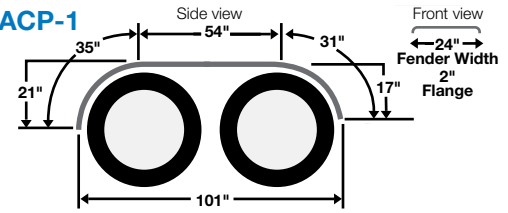

Single Axle

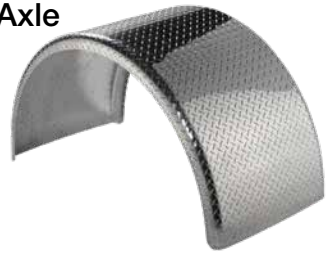

Pair Part #: **NF180ACP**
 Single Part #: **NF180ACP-1**

- ◆ .100" aluminum fender(s)
- ◆ 80" overall length
- ◆ 24" width
- ◆ Weight: 44 lbs (pair)

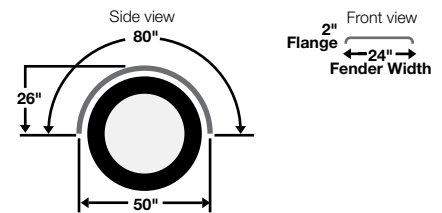

Super Single Fenders

Single Axle



Recommended mounting kit N218019SSMK

Pair Part #: **NF180SSNR19**
 Single Part #: **NF180SSNR19-1**

- ◆ 16 gauge stainless steel fender(s)
- ◆ Smooth construction
- ◆ 80" overall length
- ◆ 19" width
- ◆ Weight: 45 lbs (pair)

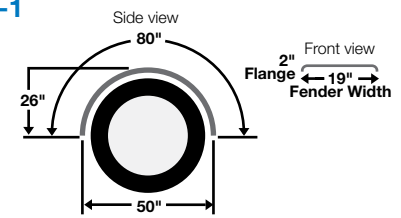

Half Tandem

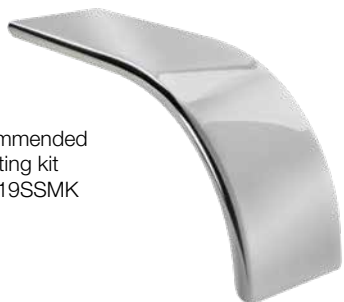

Recommended mounting kit N26019SSMK

Pair Part #: **NF72SSNR19**
 Single Part #: **NF72SSNR19-1**

- ◆ 16 gauge stainless steel fender(s)
- ◆ Smooth construction
- ◆ 72" overall length
- ◆ 19" width
- ◆ Weight: 64 lbs (pair)

